

Type F30D

Fixed displacement axial piston pump



Product documentation

2025-10-01



Structural form: single pump

Nominal pressure p_{nom} : 420 bar

Peak pressure p_{max} : 450 bar

Displacement V_{max} : 280-520 cm³/rev

Contents

| | | |
|-----------|---|-----------|
| 1 | Overview: Fixed displacement axial piston pump type F30D | 02 |
| 1.1 | General | 02 |
| 2 | Available versions, main data | 02 |
| 2.1 | Basic version | 02 |
| 3. | Dimensions | 03 |
| 3.1 | F30D-280 | 03 |
| 3.2 | F30D-520 | 05 |

1 Overview: Fixed displacement axial piston pump type F30D

1.1 General

The axial piston fixed displacement pumps of the type F30 of D offer extremely high function safety. Its remarkably low noise levels, the high pressure rating, optimized power-to-weight-ratio make it possible to employ it for most industrial.

The latest knowledge and experience with regard to noise reduction has been used in the development of this pump design. F30D is therefore rather quiet, even when taken to the limit. All components used in the V30D are manufactured from high grade materials and machined with close tolerances. The wide range of modular controllers along with a thru-shaft (option for mounting auxiliary pumps or a second V30D) open up a wide range of application possibilities.

Therefore type F30D features a pump design, which ideally suits the special requirements of modern industrial, marine, offshore, and other industries.

Features and benefits:

- Low-noise emissions
- Full torque available at the second pump in tandem pump applications

Intended applications:

- Coal mining
- Concrete pump
- Extruder
- Industrial plants
- Marine cranes and winches
- Pile driving machine
- Power pack assembly
- Presses
- Tunnel boring machine
- Ship engine



F30D

Fixed displacement axial piston pump

2 Available versions, main data

2.1 Basic version

Order coding example:

F30D 520 R D7 G N -XXXX

Internal coding

Shaft seals: N = NBR (Nitril)
V = FKM (Viton)

Mounting flange:
G=ISO 3019-2 315-8

Shaft design:
D7= **Spline shaft** (DIN 5480 W80×3×25×9g);
K5= **Parallel keyed shaft** (DIN 6885 φ80 AS 22×14×125)

Direction of rotation: R = clockwise
L = counter clockwise

Nominal size Table 1: Nominal size

Basic type

Circuit symbol:



3 Dimensions

All dimensions in mm, subject to change without notice !

3.1 F30D-280

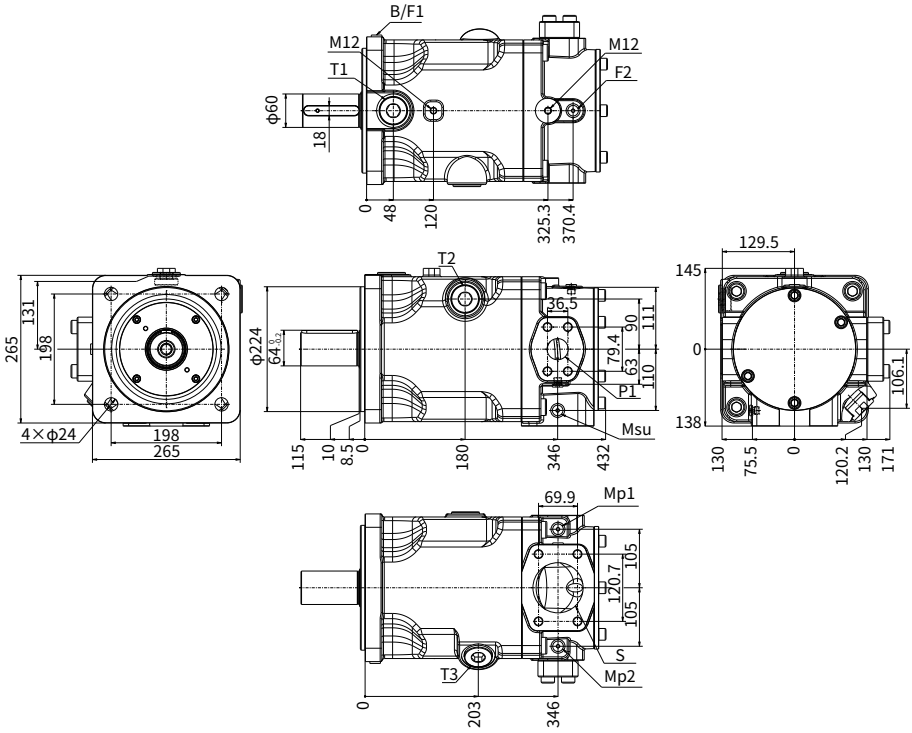

Pressure Port X

Suction Port Y

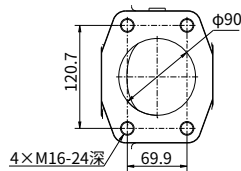
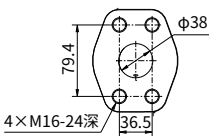

3.1 F30D-280

Shaft versions

Spline shaft
Coding D2

(DIN 5480 W60×2×28×9g)

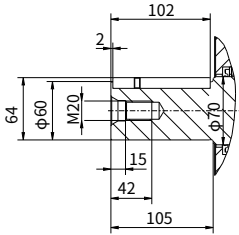

Parallel keyed shaft
Coding K4

(DIN 6885 φ60 AS 18×11×100)

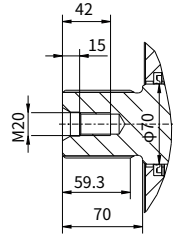

Port description

| port | description | Standard | Size | Notice |
|-------------|----------------------------------|-------------------------|-----------------------|--|
| S | Input port | SAE J518 code 61 DIN 13 | 4 in M16; 24 deep | Flange cover plate protection |
| P1 | Output port | SAE J518 code 61 DIN 13 | 1 1/2 in M16; 24 deep | Flange cover plate protection |
| P2 | Output port | SAE J518 code 61 DIN 13 | 1 1/2 in M16; 24 deep | Flange cover plate protection |
| Mp1, Mp2 | P1 and P2 outlet pressure gauges | DIN 3852-Type X | M14x1,5; 12 deep | Screw plug protection during delivery |
| Msu | Oil suction pressure tap | DIN 3852-Type X | M14x1,5; 12 deep | Screw plug protection during delivery |
| T1;T2;T3 | Drain port | DIN 3852-Type X | M42x2; 21 deep | When in use, it is necessary to connect the upper oil drain port (protected by a plastic screw plug) |
| F1; F2 | Bearing flushing hole | DIN 3852-Type X | M14x1,5; 12 deep | Refer to the instructions for flushing the oil circuit (delivered with screw plug protection) |
| B | exhaust port | DIN 3852-Type X | M14x1,5; 12 deep | When installed horizontally or vertically with the drive shaft facing upwards, it can be used for exhaust (delivered with screw plug protection) |

| | Displacement (cm ³ /rev.) | Rated pressure (bar) | Minimum oil suction pressure (bar) | Shell pressure (bar) | Self suction speed (rpm) | Minimum speed (rpm) | Temperature range (°C) | Weight (kg) |
|------------|--------------------------------------|----------------------|------------------------------------|----------------------|--------------------------|---------------------|------------------------|-------------|
| F30D - 280 | 280 | 420 | 0.85 | 2 instantaneous 3 | 1800 | 500 | -25~100 | 131 |

3.2 F30D-520

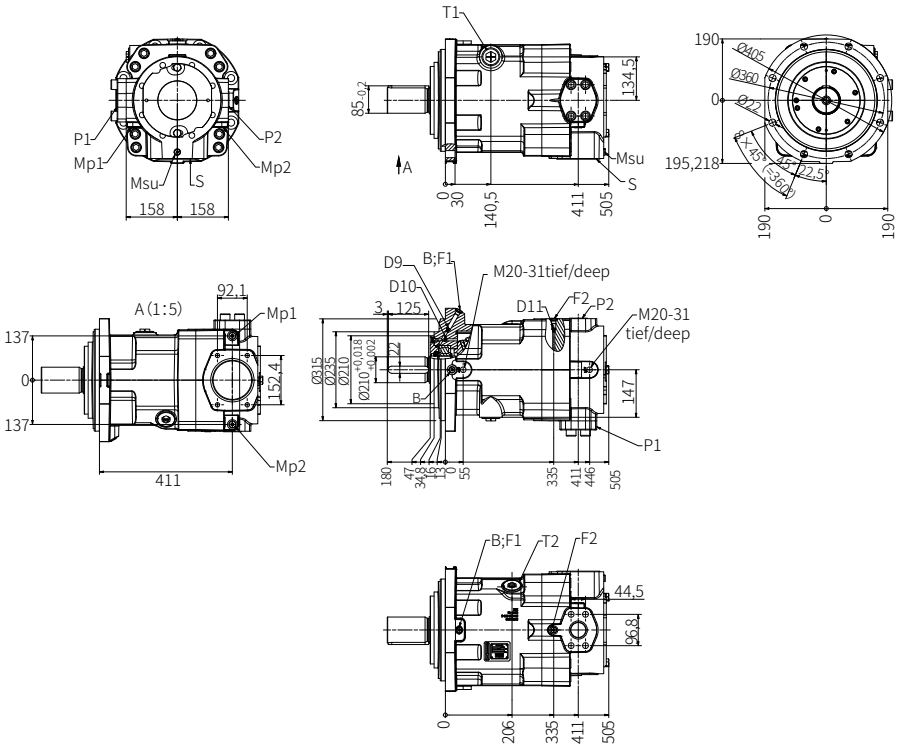

Pressure Port X

Suction Port Y

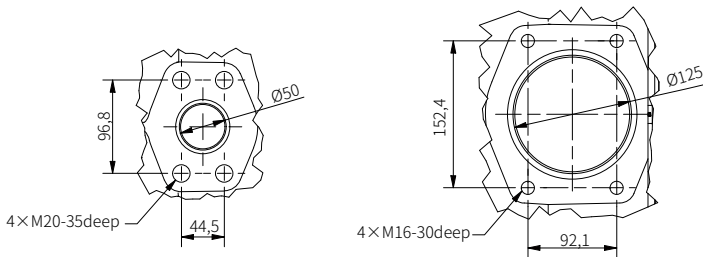

3.2 F30D-520

Shaft versions

Spline shaft Coding D7

(DIN 5480 W80×3×25×9g)

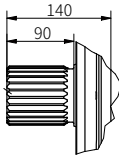

Parallel keyed shaft Coding K5

(DIN 6885 φ80 AS 22×14×125)

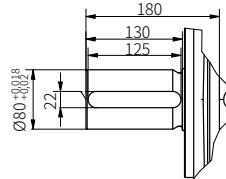

Port description

| port | description | Standard | Size | Notice |
|-------------|----------------------------------|-------------------------|-------------------|--|
| S | Input port | SAE J518 code 61 DIN 13 | 5 in M16; 30 deep | Flange cover plate protection |
| P1 | Output port | SAE J518 code 61 DIN 13 | 2 in M20; 35 deep | Flange cover plate protection |
| P2 | Output port | SAE J518 code 61 DIN 13 | 2 in M20; 35 deep | Flange cover plate protection |
| Mp1, Mp2 | P1 and P2 outlet pressure gauges | DIN 3852-Type X | M14x1,5; 12 deep | Screw plug protection during delivery |
| Msu | Oil suction pressure tap | DIN 3852-Type X | M14x1,5; 12 deep | Screw plug protection during delivery |
| T1 | Drain port | DIN 3852-Type X | M48x2; 22 deep | When in use, it is necessary to connect the upper oil drain port (protected by a plastic screw plug) |
| T2 | Drain port | DIN 3852-Type X | M48x2; 22 deep | When in use, it is necessary to connect the upper oil drain port (protected by a plastic screw plug) |
| F1; F2 | Bearing flushing hole | DIN 3852-Type X | M14x1,5; 12deep | Refer to the instructions for flushing the oil circuit (delivered with screw plug protection) |
| B | exhaust port | DIN 3852-Type X | M14x1,5; 12deep | When installed horizontally or vertically with the drive shaft facing upwards, it can be used for exhaust (delivered with screw plug protection) |

| | Displacement (cm ³ /rev.) | Rated pressure (bar) | Minimum oil suction pressure (bar) | Shell pressure (bar) | Self suction speed (rpm) | Minimum speed (rpm) | Temperature range (°C) | Weight (kg) |
|----------|--------------------------------------|----------------------|------------------------------------|----------------------|--------------------------|---------------------|------------------------|-------------|
| F30D-520 | 520 | 420 | 0.85 | 1 instantaneous 2 | 1500 | 500 | -25~100 | 252 |

© by InLine Hydraulik GmbH.

The forwarding and reproduction of this document, as well as the use and communication of its contents, are forbidden unless expressly permitted.

Any breach or infringement will result in liability for damages.

All rights reserved concerning patent or utility model registrations.